

ARTÍCULO:

## Spiders from groves in the southwestern archipelago of Finland (Araneae)

Seppo Koponen

ARTÍCULO:

### Spiders from groves in the southwestern archipelago of Finland (Araneae)

Seppo Koponen

Zoological Museum, University of Turku,  
FI-20014 Turku, Finland  
e-mail: sepkopo@utu.fi

#### Revista Ibérica de Aracnología

ISSN: 1576 - 9518.

Dep. Legal: Z-2656-2000.

Vol. 15, 30-VI-2007

Sección: Artículos y Notas.

Pp: 97 - 104.

Fecha publicación: 30 Abril 2008

Edita:

#### Grupo Ibérico de Aracnología (GIA)

Grupo de trabajo en Aracnología

de la Sociedad Entomológica

Aragonesa (SEA)

Avda. Radio Juventud, 37

50012 Zaragoza (ESPAÑA)

Tef. 976 324415

Fax. 976 535697

C-elect.: amelic@telefonica.net

Director: Carles Ribera

C-elect.: cribera@ub.edu

Índice, resúmenes, abstracts

Vols. publicados:

<http://entomologia.rediris.es/sea/publicaciones/ria/index.htm>

Página web GIA:

<http://entomologia.rediris.es/gia>

Página web SEA:

<http://entomologia.rediris.es/sea>

#### Abstract:

Spiders were studied on two islands in southwestern Finland, 2005. The study sites were luxuriant grove habitats, oak (*Quercus robur*) and hazel (*Corylus avellana*) being characteristic tree species, also old aspens (*Populus tremula*) and spruces (*Picea abies*) occur. Spiders were collected on old deciduous trees, mainly oaks, by window and branch traps and on the ground by pitfall traps. One species, *Micaria fulgens* (Walckenaer, 1802), is included in the Finnish Red Data Book. Some other rare and southern species were found, like *Clubiona comta* C. L. Koch, 1839, *Haplodrassus silvestris* (Blackwall, 1833), *Hypomma cornutum* (Blackwall, 1833), *Improphantes decolor* (Westring, 1861), *Lepthyphantes minutus* (Blackwall, 1833), *Dipoena inornata* (O. P.-Cambridge, 1861) and *Paidiscura pallens* (Blackwall, 1834). The most abundant species in the pitfall trap material are common and eurytopic in southern Finland, e.g. *Diplostyla concolor* (Wider, 1834), *Alopecosa aculeata* (Clerck, 1757) and *Pardosa lugubris* (Walckenaer, 1802). *Lepthyphantes minutus*, *Segestria senoculata* (Linnaeus, 1758) and *Paidiscura pallens* on oak trees and *Haplodrassus silvestris* on the ground were more abundant in the present study islands than in earlier studied oak groves in coastal mainland of SW Finland.

**Key words:** Spiders, Araneae, Finland, islands, grove, oak, ground layer, tree trunk, traps, faunistics

#### Arañas de los bosques del archipiélago sudoccidental de Finlandia

En el año 2005, se procedió al estudio de las arañas de dos islas de la región sudoccidental de Finlandia. Las localidades de estudio correspondieron a zonas boscosas caracterizadas por la presencia de robles (*Quercus robur*) y avellanos (*Corylus avellana*), así como chopo temblón (*Populus tremula*) y abeto rojo (*Picea abies*). Las arañas se colectaron sobre árboles caducos viejos, principalmente robles, utilizando trampas tipo "window and branch" y en suelo mediante trampas de caída. Una de las especies colectadas, *Micaria fulgens* (Walckenaer, 1802), está incluida en el libro rojo de Finlandia. También se capturaron especies raras y de distribución meridional, como *Clubiona comta* C. L. Koch, 1839, *Haplodrassus silvestris* (Blackwall, 1833), *Hypomma cornutum* (Blackwall, 1833), *Improphantes decolor* (Westring, 1861), *Lepthyphantes minutus* (Blackwall, 1833), *Dipoena inornata* (O. P.-Cambridge, 1861) y *Paidiscura pallens* (Blackwall, 1834). Sin embargo, en las trampas de caída se capturaron especies comunes y euríticas en el sur de Finlandia, como por ejemplo *Diplostyla concolor* (Wider, 1834), *Alopecosa aculeata* (Clerck, 1757) y *Pardosa lugubris* (Walckenaer, 1802). En el presente estudio, algunas especies como *Lepthyphantes minutus*, *Segestria senoculata* (Linnaeus, 1758) y *Paidiscura pallens*, en los robles, y *Haplodrassus silvestris*, en el suelo, fueron capturadas de forma más abundante que en estudios anteriores realizados en robledales de la costa continental del sur de Finlandia.

**Palabras clave:** Arañas, Araneae, Finlandia, islas, arboleda, roble, troncos de árboles, trampas, faunística.

## Introduction

The southwestern archipelago of Finland consists of over 40.000 islands or islets of different size. The spider fauna in this area has been studied e.g. by Hackman (1953), Lehtinen & Kleemola (1962), Kleemola (1963), Palmgren (1972), Palmgren & Lönnqvist (1974), Lehtinen et al. (1979), Rinne et al. (1998), Koponen (1999, 2000), Clayhills et al. (2000) and Fritzén (2002). Most of these studies have not dealt with the spiders in luxuriant groves, but some data are included in papers by Palmgren (1972), Lehtinen et al. (1979) and Rinne et al. (1998).

In the present paper, data on spiders living on the ground and on old trees (especially on oak) in two small-sized and rather isolated islands are given.

## Material and Methods

### STUDY AREA

The study islands are Hevonkack in Korpo (60°20'N, 21°35'E) and Stora Styrholm in Nagu (60°16'N, 21°49'E). The area of the islands is ca 1 and 0.5 sq. km respectively, and they are situated 30-40 km southwest of the city of Turku (Fig. 1).

The sites are luxuriant groves, oak (*Quercus robur*) and hazel (*Corylus avellana*) being characteristic trees, also old aspens (*Populus tremula*) and spruces (*Picea abies*) occur. The field and ground layer vegetation is diverse and dense. The sites studied had raised from the sea 2000-5000 years ago (land raise here is about 40 cm/100 years). These groves are included in the Finnish Natura 2000 Project.

Spiders living or moving on tree trunks or on large horizontal branches were collected using window traps on the trunks and branch traps and eclectors on branches (see Fig. 2 and Koponen, 2004). The main tree studied was oak (*Quercus robur*). Pitfall traps were used for ground-living spiders. Plastic cups (diameter 65 mm) with aluminium covers and propylene glycol and detergent were used. There were two pitfall sites on both islands: a dry and a mesic site in Hevonkack and a dry and a moist site in Stora Styrholm. There were 10 traps/site, and the trapping period was 23 May – 13 September 2005. The material studied (about 1215 identifiable specimens) is deposited in the Zoological Museum, University of Turku. Nomenclature is after Koponen (2006).

## Results and discussion

### SPECIES ON TRUNKS AND BRANCHES

Typical spider species on tree trunks (oaks and some aspens) and large branches of oak (Tables I-II) were the following (species found on both islands are marked with an asterisk): *Anyphaena accentuata* (Walckenaer, 1802)\* (Anyphaenidae), *Nuctenea umbratica* (Clerck, 1757)\* and *Zygiella stroemi* (Thorell, 1870) (Araneidae), *Clubiona comta* C. L. Koch, 1839\* (Clubionidae),

*Haplodrassus cognatus* (Westring, 1861)\* and *Micaria subopaca* Westring, 1861 (Gnaphosidae) *Agyneta innotabilis* (O. P.-Cambridge, 1863), *Drapetisca socialis* (Sundevall, 1833)\*, *Entelecara erythropus* (Westring, 1851), *Hypomma cornutum* (Blackwall, 1833), *Lepthyphantes minutus* (Blackwall, 1833)\*, *Moebelia penicillata* (Westring, 1851)\*, *Neriene montana* (Clerck, 1757)\* and *Thyreosthenius parasiticus* (Westring, 1851) (Linyphiidae), *Philodromus margaritatus* (Clerck, 1757)\* (Philodromidae), *Pseudeuophrys erratica* (Walckenaer, 1826)\* and *Salticus cingulatus* (Panzer, 1797)\* (Salticidae), *Segestria senoculata* (Linnaeus, 1758)\* (Segestriidae), *Keijia tinctoria* (Walckenaer, 1802), *Paidiscura pallens* (Blackwall, 1834)\*, *Steatoda bipunctata* (Linnaeus, 1758)\* and *Theridion mystaceum* L. Koch, 1870\* (Theridiidae) and *Ozyptila praticola* C. L. Koch, 1837\* (Thomisidae). Most of them have been reported commonly from tree trunks in different parts of Europe (see Szinetár & Horváth, 2006). The following species are considered as exclusive bark-dwellers by Szinetár & Horváth (2006): *Haplodrassus cognatus*, *Micaria subopaca*, *Agyneta innotabilis*, *Drapetisca socialis*, *Lepthyphantes minutus*, *Moebelia penicillata*, *Philodromus margaritatus* and *Theridion mystaceum*.

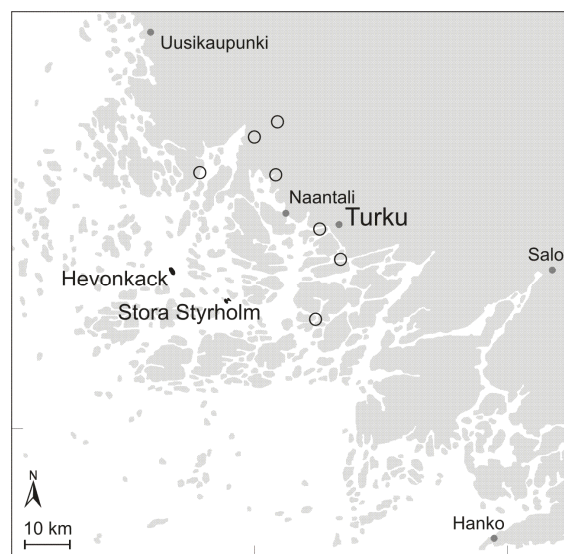

**Fig. 1.** Study islands, Hevonkack and Stora Styrholm, in SW Finland. The earlier studied oak groves in coastal mainland zone (Rinne et al., 1998) are shown by open circles.

The spiders collected by window traps (tree trunk species) are shown in Table I and those found by branch traps/eclectors (branch species) in Table II. *Lepthyphantes minutus*, the clear dominant in window traps was caught in good numbers also in branch traps. Other abundant species in both traps included *Haplodrassus cognatus* and *Salticus cingulatus*. Generally, the composition of dominant species in window and branch traps

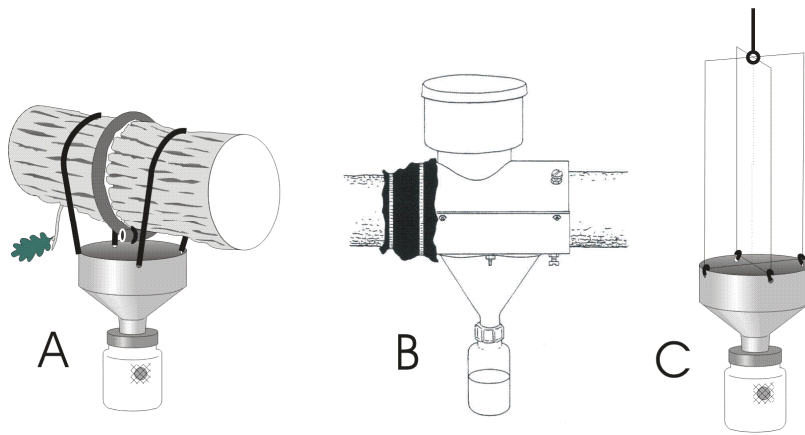

**Fig. 2** Traps used for tree-dwelling spiders. A: branch trap (Koponen et al., 1997), B: branch eclector (Simon, 1995), C: window trap (Rinne et al., 1998).

was rather different. The following spiders are rarely collected and southern species in Finland (cf. Lehtinen et al., 1979; Palmgren, 1972; Rinne et al., 1998): *Clubiona comta*, *Hypomma cornutum*, *Lepthyphantes minutus*, *Paidiscura pallens* and *Dipona inornata* (O. P.-Cambridge, 1861). Of the collected spiders, *Lepthyphantes minutus* (Linyphiidae), *Paidiscura pallens* (Theridiidae) and *Segestria senoculta* (Segestriidae) were here clearly more abundant than in the earlier studied oak groves in the coastal mainland zone of SW Finland (Koponen et al., 1997; Rinne et al., 1998). The present spider material from oak trees ("oak fauna") is, compared with that from the mainland oak groves around Turku (Rinne et al., 1998; Koponen, 2004), less diverse. This is probably caused by the isolation, small size and young age (due to land raise) of the islands, and on the other hand also by the structure of the studied groves. In and near the mainland, oak forms more or less pure small woodlands, and in the present islands it is growing in mixed stands with aspen, spruce, etc.

#### SPECIES COLLECTED ON THE GROUND

The most abundant species in pitfall trap material are shown in Table III and the total material in Tables IV-V. Clear differences can be seen in species composition from dry, mesic and moist groves. The most abundant species in dry oak sites were (after their abundance) *Alopecosa aculeata* (Clerck, 1757) and *Pardosa lugubris* (Walckenaer, 1802) (Lycosidae), *Diplostyla concolor* (Wider, 1834) (Linyphiidae), *Haplodrassus silvestris* (Blackwall, 1833) (Gnaphosidae), *Anguliphantes angulipalpis* (Westring, 1851), *Microneta viaria* (Blackwall, 1841) and *Tapinocyba pallens* (O. P.-Cambridge, 1872) (Linyphiidae); in the mesic site *Diplostyla concolor*, *Walckenaeria atrotibialis* (O. P.-Cambridge, 1878), *Ceratinella brevis* (Wider, 1834), *Tenuiphantes tenebricola* (Wider, 1834) and *Dicymbium tibiale* (Blackwall, 1836) (Linyphiidae), *Trochosa terricola* Thorell, 1856 (Lycosidae), *Ozyptila praticola* (C. L. Koch, 1837) (Thomisidae) and *Haplodrassus silvestris* (Gnaphosidae); and in the moist site *Pirata hygrophilus* Thorell, 1872 (Lycosidae), *Diplostyla concolor* and *Tenuiphantes tenebricola* (Linyphiidae), *Zora*

*spinimana* (Sundevall, 1833) (Zoridae), *Bathyphantes parvulus* (Westring, 1851) and *Microneta viaria* (Linyphiidae).

In general, the most abundant species in pitfalls are rather common in southern Finland and can be found in different habitats. The most dominant species, *Diplostyla concolor*, is known from a diversity of forest and meadow habitats, even in human-influenced sites (cf. also Hänggi et al., 1995). The only southern rare species in Finland, caught in good numbers was *Haplodrassus silvestris*, 4.5 % of all trapped spiders (Table III) Other rare ground layer species were *Improphantes decolor* (Westring, 1861) and *Micaria fulgens*, the latter species is included in the Finnish Red Data Book (NT; Rassi et al., 2001). A female of both species was found in the dry oak forest site on Hevonkack. *Improphantes decolor* is an interesting species, which seems to have great fluctuations in abundance, at least in Finland. It was commonly found in 1970s in southwestern Finland (e.g. Lehtinen et al., 1979), but after that it has been observed only rarely. However, I found the species in the mid-1990s from two islands in the Finnish archipelago (Koponen, 2000). Its distribution area is large, from mountains of Algeria to Fennoscandia (Moritz, 1968; Bosmans, 1985; Thaler, 1986), but it has been collected only seldom. Thaler (1986) regarded *I. decolor* as a mediterranean-expansive species, widely-distributed but neglected.

#### Acknowledgements

I wish to thank Veikko Rinne and Tom Clayhills for help in field work, Tanja Kyykkä for sorting the material, and Leif Lindgren and the Finnish Forest and Park Service (Metsähallituksen Etelä-Suomen luontopalvelut) for logistics and other support.

## References

- BOSMANS, R. 1985. Les genres *Troglohyphantes* Joseph and *Lepthyphantes* Menge en Afrique du Nord (Araneae, Linyphiidae). *Revue arachnologique*, **6**: 135-178.
- CLAYHILLS, T., RINNE, V. & KOPONEN, S. 2000. Arthropods in the Southwestern Archipelago National Park: beetles, bugs and spiders in heritage landscapes and sandy islands. *Metsähallituksen luonnonsuojelujulkaisuja*, **A 113**: 1-87. [in Finnish]
- FRITZÉN, N.R. 2002. *Hyptiotes paradoxus* (Araneae: Uloboridae) found on the Åland Islands. A species new to Finland. *Memoranda Societatis pro Fauna et Flora Fennica*, **78**: 3-7.
- HACKMAN, W. 1953. Spiders from Åland and the southwestern archipelago of Finland. *Memoranda Societatis pro Fauna et Flora Fennica*, **28**: 70-78. [in Swedish]
- HÄNGGI, A., STÖCKLI, E. & NENTWIG, W. 1995. Habitats of Central European spiders. *Miscellanea Faunistica Helvetica*, **4**: 1-460.
- KLEEMOLA, A. 1963. On the zonation of spiders on stony shores of rocky islets in the southwestern archipelago of Finland. *Aquilo (Zoologica)*, **1**: 26-38.
- KOPONEN, S. 1999. Three species of spiders (Araneae) new to the fauna of Finland from the southwestern archipelago. *Entomologica Fennica*, **10**: 6.
- KOPONEN, S. 2000. Spiders (Araneae) on sandy islands in the southwestern archipelago of Finland. *Ekologia (Bratislava)*, **19**, **Suppl. 4**: 79-85.
- KOPONEN, S. 2004. Arthropods from high oak branches – comparison of two trap types, with a special reference to spiders. *Latvijas Entomologs*, **41**: 71-75.
- KOPONEN, S. 2006. *Checklist of spiders in Finland (Araneae)*. at: [http://users.utu.fi/sepkopo/checklist\\_of\\_spiders\\_in\\_Finland.htm](http://users.utu.fi/sepkopo/checklist_of_spiders_in_Finland.htm)
- KOPONEN, S., RINNE, V. & CLAYHILLS, T. 1997. Arthropods on oak branches in SW Finland, collected by a new trap type. *Entomologica Fennica*, **8**: 177-183.
- LEHTINEN, P.T. & KLEEMOLA, A. 1962. Studies on the spider fauna of the southwestern archipelago of Finland. I. *Archivum Societatis Zoologicae Botanicae Fennicae 'Vanamo'*, **16(1)**: 97-114.
- LEHTINEN, P.T., KOPONEN, S. & SAARISTO, M. 1979. Studies on the spider fauna of the southwestern archipelago of Finland. II. The Åland mainland and the island of Eckerö. *Memoranda Societatis pro Fauna et Flora Fennica*, **55**: 33-52.
- MORITZ, M. 1968. *Lepthyphantes zebrinus* (Menge), ein Wiederfund für die deutsche Spinnenfauna (Araneae, Linyphiidae). *Deutsche Entomologische Zeitschrift, N.F.*, **15**: 399-407.
- PALMGREN, P. 1972. Studies on the spider populations of the surroundings of the Tvärminne Zoological Station, Finland. *Societas Scientiarum Fennica, Commentationes Biologicae*, **52**: 1-133.
- PALMGREN, P. & LÖNNQVIST, B. 1974. The spiders of some habitats at the Nåtö Biological Station (Åland, Finland). *Societas Scientiarum Fennica, Commentationes Biologicae*, **73**: 1-10.
- RASSI, P., ALANEN, A., KANERVA, T. & MANNERKOSKI, I. (Eds) 2001. *The 2000 Red List of Finnish species*. Ministry of Environment. Helsinki, 432 pp.
- RINNE, V., CLAYHILLS, T. & KOPONEN, S. 1998. Invertebrates of protected oak groves in southwestern Finland. *Metsähallituksen luonnonsuojelujulkaisuja*, **A 90**: 1-76. [in Finnish]
- SIMON, U. 1995. *Untersuchungen der Stratozönosen von Spinnen und Weberknechten (Arachn.: Araneae, Opilionida) an der Waldkiefer (Pinus sylvestris L.)*. Wissenschaft und Technik Verlag Gross, Berlin, 142 pp.
- SZINETÁR, C. & HORVÁTH, R. 2006. A review of spiders on tree trunks in Europe (Araneae). European Arachnology 2005 (DELTSHEV, C. & STOEV, P., eds): *Acta Zoologica Bulgarica*, **Suppl. 1**: 221-257.
- THALER, K. 1986. Vier bemerkenswerte *Lepthyphantes*-Arten aus dem Mittelmeergebiet und aus Vorderasien (Arachnida: Aranei, Linyphiidae). *Sitzungsberichte der Österreichischen Akademie der Wissenschaften, Mathem.-naturw. I*. **194**: 311-325.

**Table I.**

Spiders collected on tree trunks by windows traps (H = Hevonkack, S = Stora Styrholm).

Species	Family	H	S	Total
<i>Lepthyphantes minutus</i>	Linyph.	14	10	24
<i>Segestria senoculata</i>	Segestr.	6	6	12
<i>Theridion mystaceum</i>	Therid.	1	7	8
<i>Paidiscura pallens</i>	Therid.	4	3	7
<i>Haplodrassus cognatus</i>	Gnaph.	4	3	7
<i>Neriene montana</i>	Linyph.	1	5	6
<i>Drapetisca socialis</i>	Linyph.	1	5	5
<i>Pelecopsis elongata</i>	Linyph.	4	-	4
<i>Pseudeuophrys erratica</i>	Saltic.	-	4	4
<i>Salticus cingulatus</i>	Saltic.	3	1	4
<i>Entelecara erythropus</i>	Linyph.	3	-	3
<i>Anyphaena accentuata</i>	Anyph.	1	1	2
<i>Zygiella stroemi</i>	Araneid.	2	-	2
<i>Cryphoeca silvicola</i>	Hahniid.	2	-	2
<i>Linyphia triangularis</i>	Linyph.	1	1	2
<i>Achaearana lunata</i>	Therid.	-	2	2
<i>Steatoda bipunctata</i>	Therid.	1	1	2
<i>Theridion varians</i>	Therid.	1	1	2
<i>Araneus diadematus</i>	Araneid.	1	-	1
<i>Nuctenea umbratica</i>	Araneid.	1	-	1
<i>Clubiona comta</i>	Clubion.	-	1	1
<i>C. neglecta</i>	Clubion.	-	1	1
<i>Gnaphosa</i> sp.	Gnaph.	-	1	1
<i>Micaria</i> sp.	Gnaph.	1	-	1
<i>Agyneta conigera</i>	Linyph.	1	-	1
<i>A. innotabilis</i>	Linyph.	1	-	1
<i>Entelecara acuminata</i>	Linyph.	1	-	1
<i>Moebelia penicillata</i>	Linyph.	1	-	1
<i>Neriene clathrata</i>	Linyph.	-	1	1
<i>Pityohyphantes phrygianus</i>	Linyph.	-	1	1
<i>Thyreosthenius parasiticus</i>	Linyph.	1	-	1
<i>Ero</i> sp.	Mimet.	1	-	1
<i>Philodromus</i> sp.	Philodr.	1	-	1
<i>Metellina mengei</i>	Tetrag.	-	1	1
<i>Tetragnatha dearmata</i>	Tetrag.	-	1	1
<i>Dipoena inornata</i>	Therid.	-	1	1
<i>Zora spinimana</i>	Zorid.	.	-	1
Total species		26	22	37

**Table II.**

Spiders collected on large branches of oak by branch traps and eclectors (H = Hevonkack, S = Stora Styrholm)

Species	Fam.	H	S	Total
<i>Nuctenea umbratica</i>	Araneid.	8	3	11
<i>Anyphaena accentuata</i>	Anyph.	8	2	10
<i>Hypomma cornutum</i>	Linyph.	10	-	10
<i>Araneus diadematus</i>	Araneid.	9	-	9
<i>Lepthyphantes minutus</i>	Linyph.	5	4	9
<i>Philodromus margaritatus</i>	Philodr.	6	3	9
<i>Xysticus ulmi</i>	Thomis.	8	-	8
<i>Haplodrassus cognatus</i>	Gnaph.	6	1	7
<i>Clubiona pallidula</i>	Clubion.	7	-	7
<i>Moebelia penicillata</i>	Linyph.	5	2	7
<i>Salticus cingulatus</i>	Saltic.	6	1	7
<i>Keijia tincta</i>	Therid.	6	-	6
<i>Neriene montana</i>	Linyph.	-	3	3
<i>Drapetisca socialis</i>	Linyph.	2	-	2
<i>Zygiella stroemi</i>	Araneid.	1	-	1
<i>Micaria subopaca</i>	Gnaph.	1	-	1
<i>Dismodicus elevatus</i>	Linyph.	1	-	1
<i>Entelecara erythropus</i>	Linyph.	1	-	1
<i>Neriene clathrata</i>	Linyph.	-	1	1
<i>Tenuiphantes tenebricola</i>	Linyph.	1	-	1
<i>Pseudeuophrys erratica</i>	Saltic.	-	1	1
<i>Heliophanus</i> sp.	Saltic.	1	-	1
<i>Segestria senoculata</i>	Segestr.	1	-	1
<i>Enoplognatha ovata</i>	Therid.	-	1	1
<i>Paidiscura pallens</i>	Therid.	1	-	1
<i>Theridion mystaceum</i>	Therid.	1	-	1
Total species		22	11	26

**Table III.**

The most abundant species in pitfall trap material (all four sites).

<i>Diplostyla concolor</i>	174	17.9
<i>Alopecosa aculeata</i>	70	7.2
<i>Pardosa lugubris</i>	69	7.1
<i>Pirata hygrophilus</i>	58	6.0
<i>Tenuiphantes tenebricola</i>	51	5.2
<i>Ceratinella brevis</i>	50	5.1
<i>Microneta viaria</i>	44	4.5
<i>Haplodrassus silvestris</i>	44	4.5
<i>Anguliphantes angulipalpis</i>	39	4.0
<i>Tapinocyba pallens</i>	30	3.1
Others 53 species		

**Table IV.**  
Spiders collected by pitfall traps on Hevonkack.

Species	Fam.	Dry	Mesic hazel	Total
<i>Diplostyla concolor</i>	Linyph.	10	96	106
<i>Alopecosa aculeata</i>	Lycos.	56	5	61
<i>Pardosa lugubris</i>	Lycos.	45	5	50
<i>Ceratinella brevis</i>	Linyph.	28	20	48
<i>Haplodrassus silvestris</i>	Gnaph.	30	6	36
<i>Microneta viaria</i>	Linyph.	19	3	22
<i>Anguliphantes angulipalpis</i>	Linyph.	21	1	22
<i>Walckenaeria atrotibialis</i>	Linyph.	-	22	22
<i>Tapinocyba pallens</i>	Linyph.	16	5	21
<i>Walckenaeria dysderoides</i>	Linyph.	15	1	16
<i>Zora nemoralis</i>	Zorid.	15	-	15
<i>Trochosa terricola</i>	Lycos.	5	8	13
<i>Walckenaeria cucullata</i>	Linyph.	13	-	13
<i>Haplodrassus signifer</i>	Gnaph.	11	1	12
<i>H. umbratilis</i>	Gnaph.	11	-	11
<i>Zelotes clivicola</i>	Gnaph.	10	1	11
<i>Tenuiphantes tenebricola</i>	Linyph.	-	11	11
<i>Dicymbium tibiale</i>	Linyph.	-	11	11
<i>Zora spinimana</i>	Zorid.	9	-	9
<i>Ozyptila praticola</i>	Thomis.	-	7	7
<i>Gnaphosa bicolor</i>	Gnaph.	6	1	7
<i>Zelotes latreillei</i>	Gnaph.	6	-	6
<i>Euryopsis flacomaculata</i>	Therid.	6	-	6
<i>Pocadicnemis pumila</i>	Linyph.	6	-	6
<i>Neriere clathrata</i>	Linyph.	4	1	5
<i>Micaria pulicaria</i>	Gnaph.	5	-	5
<i>Hahnia ononidum</i>	Hahn.	5	-	5
<i>Phrurolithus festivus</i>	Lioer.	4	-	4
<i>Pachygnatha listeri</i>	Tetrag.	3	-	3
<i>Walckenaeria antica</i>	Linyph.	3	-	3
<i>Agyneta ramosa</i>	Linyph.	-	3	3
<i>Cryphoea silvicola</i>	Hahn.	-	3	3
<i>Robertus lividus</i>	Therid.	-	3	3
<i>Drassyllus praeficus</i>	Gnaph.	1	1	2
<i>Hahnia pusilla</i>	Hahn.	2	-	2
<i>Bathypantes parvulus</i>	Linyph.	-	2	2
<i>Centromerus sylvaticus</i>	Linyph.	-	2	2
<i>Micrargus herbigradus</i>	Linyph.	2	-	2
<i>Xysticus ulmi</i>	Thomis.	2	-	2
<i>Micaria aenea</i>	Gnaph.	1	-	1
<i>M. fulgens</i>	Gnaph.	1	-	1
<i>Agyneta conigera</i>	Linyph.	-	1	1
<i>Ceratinella scabrosa</i>	Linyph.	-	1	1
<i>Diplocephalus picinus</i>	Linyph.	1	-	1
<i>Improphantes decolor</i>	Linyph.	1	-	1
<i>Macrargus rufus</i>	Linyph.	1	-	1
<i>Porrhomma pallidum</i>	Linyph.	-	1	1
<i>Ero furcata</i>	Mimet.	1	-	1
<i>Crustulina guttata</i>	Therid.	1	-	1
<i>Ozyptila trux</i>	Thomis.	-	1	1
<b>Total species</b>		37	28	50

Table V. Spiders collected by pitfall traps on Stora Styrholm.

Species	Fam.	Dry	Moist oak-aspen	Total
<i>Diplostyla concolor</i>	Linyph.	44	24	68
<i>Pirata hygrophilus</i>	Lycos.	2	56	58
<i>Tenuiphantes tenebricola</i>	Linyph.	29	11	40
<i>Microneta viaria</i>	Linyph.	16	6	22
<i>Pardosa lugubris</i>	Lycos.	19	-	19
<i>Anguliphantes angulipalpis</i>	Linyph.	16	1	17
<i>Zora spinimana</i>	Zorid.	8	7	15
<i>Alopecosa aculeata</i>	Lycos.	9	-	9
<i>Tapinocyba pallens</i>	Linyph.	8	1	9
<i>Haplodrassus silvestris</i>	Gnaph.	7	1	8
<i>Bathypantes parvulus</i>	Linyph.	-	7	7
<i>Haplodrassus umbratilis</i>	Gnaph.	6	-	6
<i>Agyneta ramosa</i>	Linyph.	4	1	5
<i>Trochosa terricola</i>	Lycos.	2	3	5
<i>Neriere clathrata</i>	Linyph.	4	-	4
<i>Diplocephalus picinus</i>	Linyph.	3	1	4
<i>Hahnia pusilla</i>	Hahn.	1	3	4
<i>Walckenaeria atrotibialis</i>	Linyph.	-	4	4
<i>Agroeca proxima</i>	Liocr.	3	-	3
<i>Pachygnatha listeri</i>	Tetrag.	-	3	3
<i>Hahnia ononidum</i>	Hahn.	2	-	2
<i>Centromerus arcanus</i>	Linyph.	-	2	2
<i>C. sylvaticus</i>	Linyph.	-	2	2
<i>Ceratinella brevis</i>	Linyph.	2	-	2
<i>Walckenaeria cucullata</i>	Linyph.	1	1	2
<i>Cercidia prominens</i>	Arneid.	1	-	1
<i>Zelotes clivicola</i>	Gnaph.	1	-	1
<i>Agyneta conigera</i>	Linyph.	-	1	1
<i>A. subtilis</i>	Linyph.	1	-	1
<i>Helophora insignis</i>	Linyph.	-	1	1
<i>Linyphia triangularis</i>	Linyph.	-	1	1
<i>Maso sundevalli</i>	Linyph.	-	1	1
<i>Microlinyphia pusilla</i>	Linyph.	1	-	1
<i>Tenuiphantes cristatus</i>	Linyph.	-	1	1
<i>Walckenaeria dysderoides</i>	Linyph.	1	-	1
<i>W. obtusa</i>	Linyph.	-	1	1
<i>Phrurolithus festivus</i>	Liocr.	1	-	1
<i>Ero furcata</i>	Mimet.	-	1	1
<i>Pachygnatha clercki</i>	Tetrag.	1	-	1
<i>Robertus lividus</i>	Therid.	-	1	1
<i>Ozyptila praticola</i>	Thomis.	1	-	1
<i>O. trux</i>	Thomis.	1	-	1
<i>Zora nemoralis</i>	Zorid.	1	-	1
Total species		30	26	43